

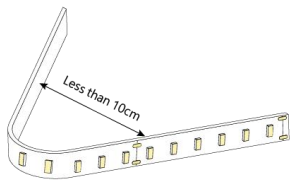

ATTENTION: This product should be installed by a professional licensed electrician.

Warnings

- 1 Verify all products are accounted for and in good condition. If not, skip installation instructions and see contact information at the bottom.
- 2 Please check local electrical codes.
- 3 Turn power off before installing, and make sure to use properly rated wire.
- 4 Modifying or not following instructions will void the warranty for this product.
- 5 Please read the instructions entirely before starting installation.
- 6 Confirm the work voltage and make sure to use qualified driver.
- 7 Connect and cut this product correctly. Any wrong operation will damage this product.
- 8 The most suitable operation temperature shall be $-40\sim 60^{\circ}\text{C}$ ($-40\sim 140^{\circ}\text{F}$). DO NOT operate light when ambient temperature exceeds this range.
- 9 Please make sure the product does not stick with any paper related material directly.
- 10 For specifications that call for more intricate installations, please don't hesitate to contact us at info@beamever.com.

 Bend the tapelight to a diameter less than 10cm



 Fold, crease, twist, or bend the tapelight at sharp angles

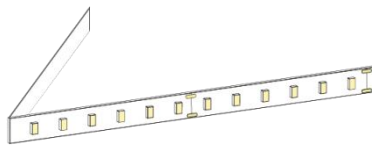

 Bend the tapelight horizontally

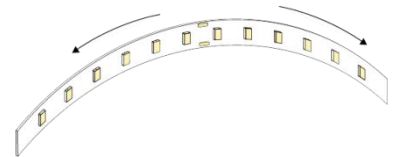

 Trample on the tapelight

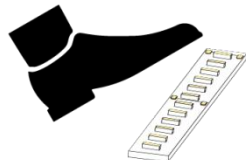

 Power without removing from the spool

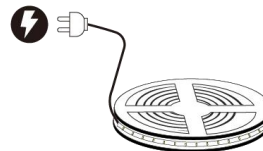

Cutting Instruction

- Disconnect power at the source prior to attempting installation.
- Place the light horizontally when cutting it.
- Cutting the tapelight without using an appropriate end cap will reduce its IP rating to IP20. For more instructions, please contact your sales representatives or refer to the standalone install manual of the end caps.

Step 1 Determine the desired location of the cut based on the cutting increments marked on the product, with cut marks facing upwards.

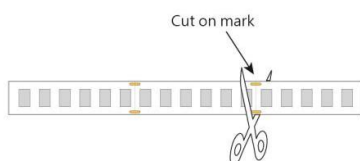

Step 2 Gently cut straight down through the body of the product directly on the cutting increment mark. DO NOT cut diagonally or horizontally as this may damage the product.

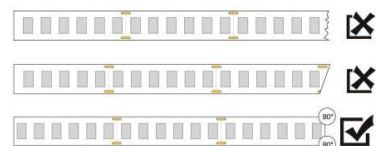

Installing Tapelight

- Before installing the tapelight, determine the desired location and lengths, and leave enough distance from power cable to reach the driver.
- Clear the mounting surface and remove any dirt, debris and moisture.

01 Installing with 3M tape

Step 1 Peel off the 3M tape on the back of the tape, and gently attach tape to the mounting surface from one direction.

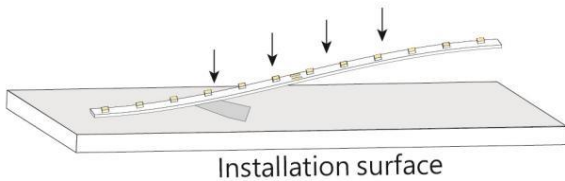

Step 2 Gently press the tape back and forth to make sure that it's flat and firm without any air pockets.

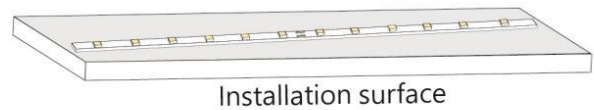

02 Installing with channel

Step 1 Install the mounting clips into position with screws. It is recommended to use ONE mounting clip for 30cm of the neon.

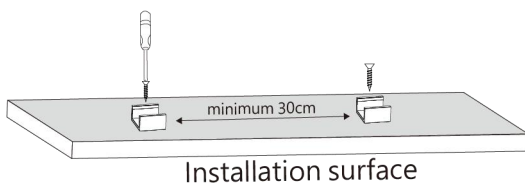

Step 2 Install channel into mounting clips. Make sure that the channel securely snaps onto the mounting clips.

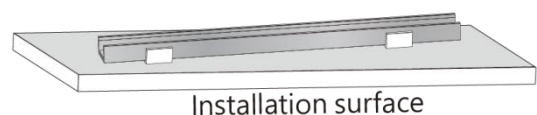

Step 3 Peel off the 3M tape on the back of the tape, and gently attach tape into the channel from one direction.

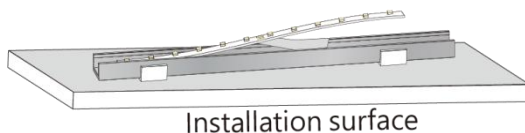

Step 4 Gently press the tapelight back and forth to make sure that it's flat and firm without any air pockets. Install lens onto the channel.

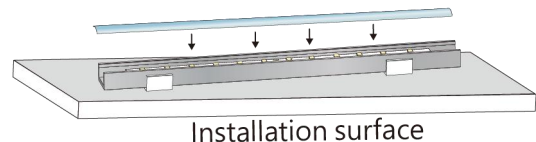

Step 5 Install end caps on both ends.

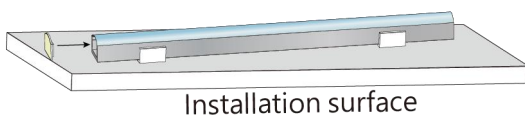

Wiring Diagram

Non-dimmable System

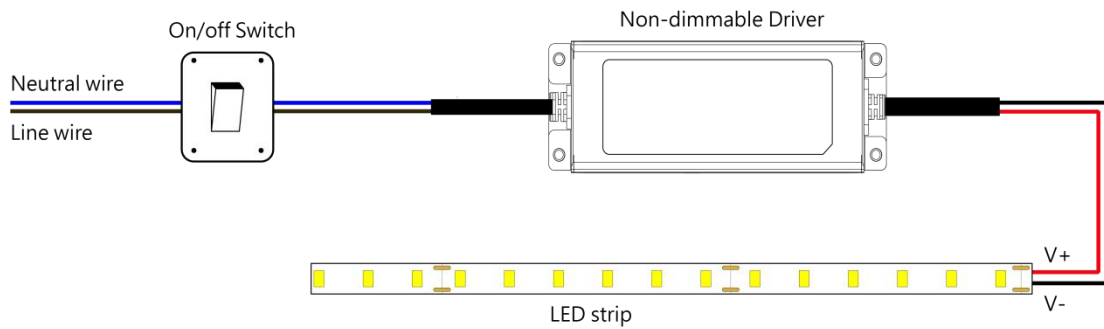

Single Color Dimmable System

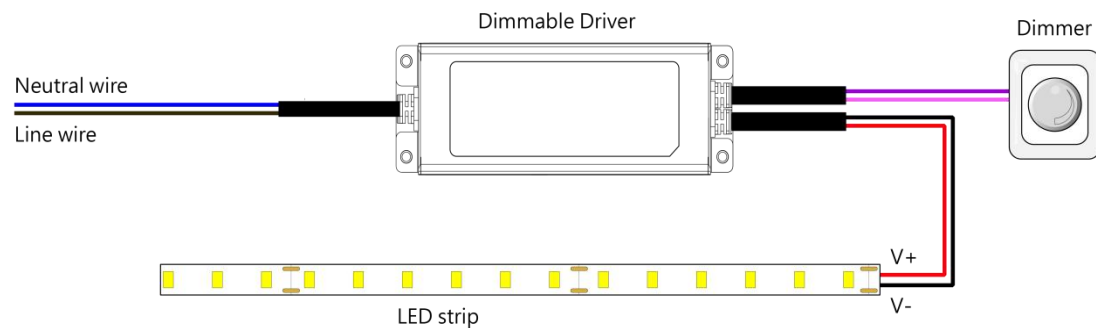

Color-changing Mini Control System

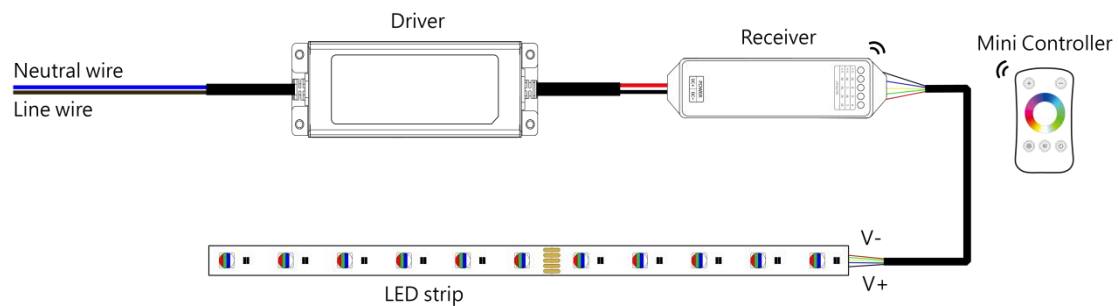

Color-changing DMX Control System

